



A founding member of AEFAC



**Anchor testing to SA TS101:2015
Appendix B performed by
Melbourne Testing Services, a
“NATA Accredited Laboratory”
Report Number: MTS-16-226-285**

Fastener Technical Assessment	FTA-16/0001 of 01/08/2016
--------------------------------------	--------------------------------------

This Technical Assessment meets the testing requirements stipulated in Standards Australia Technical Specification: SA TS101:2015	
Trade name of the construction product	ChemSet™ Reo 502™ steel bonded anchor
Product family to which the construction product belongs	Bonded injection type anchor for use in non-cracked concrete
Manufacturer	ramsetreid™ 1 Ramset Drive Chirside Park Vic 3116 Australia
Manufacturing plant	ITW Australia Pty Ltd (ramsetreid™)
This Technical Assessment contains	12 pages including 9 Annexes which form an integral part of this assessment.
This Technical Assessment is issued in accordance with Standards Australia SA TS101:2015, on the basis of	Compliance to testing for suitability and admissible service conditions in accordance with SA TS101:2015 Appendix B

1. Technical description of the product

The ChemSet™ Reo502™ (faster curing time) and ChemSet™ Reo502™EF (extended processing time) is used with steel elements as a bonded anchor (injection type).

Steel elements in this report are rebar.

The steel element is placed into a drilled hole filled with injection mortar and is anchored via the bond between metal part, injection mortar and concrete. The anchor is intended to be used with embedment depth from 8 bar diameters to 20 bar diameters.

The illustration and the description of the product are given in Annex A.

2. Specification of intended use

The performances given in Section 3 are only valid if the anchor is used in compliance with the specifications and conditions given in Annex B.

The provisions made in this Technical Assessment are based on an assumed working life of the anchor of 50 years. The indications given on the working life cannot be interpreted as a guarantee given by the producer, but are to be regarded only as a means for choosing the products in relation to the expected economically reasonable working life of the works.

3. Performance of the product and references to the methods used for its assessment

3.1 Mechanical resistance and stability

Essential characteristic	Performance
Characteristic resistance for tension loads - rebar	See Annex C 1
Characteristic resistance for shear loads - rebar	See Annex C 2

The information published in this document reflects a true representation of performance in typical Australian and New Zealand concrete substrates including Flyash.

4. Material Safety Data Sheet

Refer to MSDS Chemwatch 41-8662 (REO502) and Chemwatch 4784-68 (REO502EF) for Safety Data Sheet according to WHS and ADG requirements.

Reinforcing bar

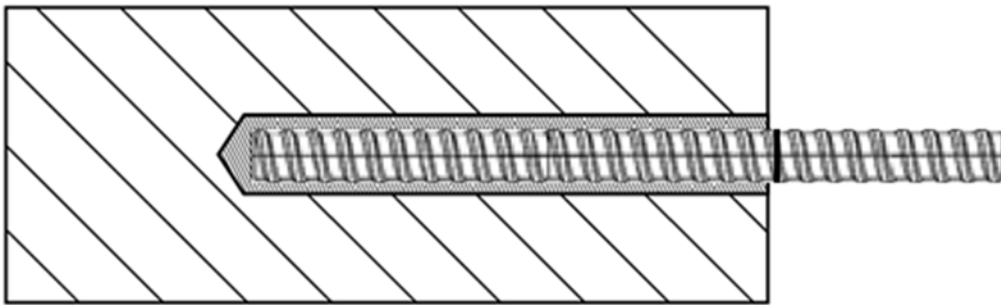
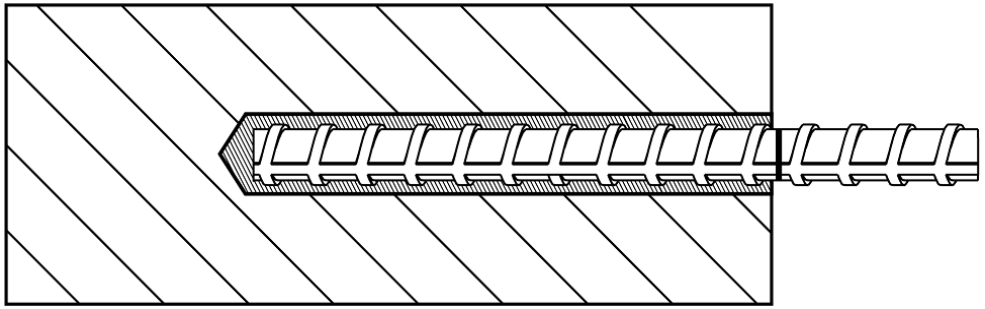

ChemSet™ Reo 502™, ChemSet™ Reo 502™EF

Product description
Installed conditions

Annex A 1

Coaxial cartridge (Coax)

ChemSet™ Reo502™ 600 ml



ChemSet™ Reo 502™EF 600 ml



Marking of the mortar cartridges

Identifying mark of the producer, Trade name, Part/Order number, Storage life, Curing and processing time

Mixing nozzle

ISNET



ISNE



Dosing Cap



Dosing Cap			
Description	To Suit Hole Diameters	Part Number	Pack Quantity
Dosing Cap	15, 18, 20, 25, 30, 40 mm	055969	5

ChemSet™ Reo 502™, ChemSet™ Reo 502™EF

Product description
Injection system

Annex A 2

Reinforcing bar Ø12, Ø16, Ø20, Ø24, Ø25

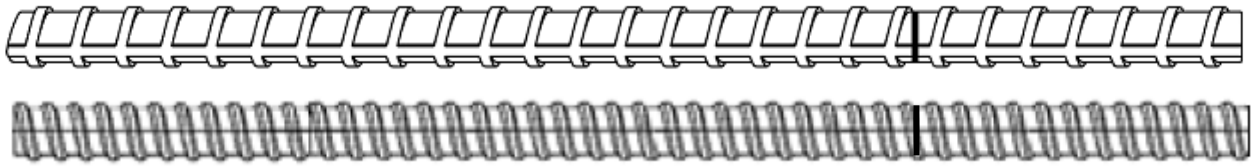

Commercial reinforcing (N Class) bar to AS/NZS 4671:2001 with marked embedment depth

Product Characteristics	Value
Characteristic yield strength f_{yf} (MPa)	500
Characteristic Minimum Ultimate to Yield ratio - f_{ut}/f_{yf}	1.08

ChemSet™ Reo 502™, ChemSet™ Reo 502™EF

Product description
Rebars and materials

Annex A 3

Specifications of intended use

Anchorage subject to:

- Static and quasi-static load.

Base materials

- Non-cracked concrete for rebars $\varnothing 12$ to $\varnothing 25$.
- Reinforced or unreinforced normal weight concrete according to AS1379-2007 of strength class $f'c = 20$ MPa at minimum and $f'c = 50$ MPa for use in construction in accordance with AS3600-2009.

Temperature range:

- -40°C to $+40^{\circ}\text{C}$ (max. short. term temperature $+40^{\circ}\text{C}$ and max. long term temperature $+24^{\circ}\text{C}$)

Use categories:

- Category 2 – installation in dry or wet concrete or in flooded hole.

Design:

- The anchorages are designed in accordance with the Standards Australia SA TS101:2015 “Design of post-installed and cast in fixings” under the responsibility of an engineer experienced in anchorages and concrete work.
- Verifiable calculation notes and drawings are prepared taking into account the loads to be anchored. The position of the anchor is indicated on the design drawings.

Installation:

- Dry or wet concrete or flooded hole.
- Hole drilling by hammer drill mode or diamond core drill mode.
- Anchor installation carried out by appropriately qualified personnel and under the supervision of the person responsible for technical matters of the site.

ChemSet™ Reo 502™, ChemSet™ Reo 502™EF

Intended use
Specifications

Annex B 1

Applicator gun

A



A1



B



Applicator gun	A	A1	B
Cartridge	Coax 600	Coax 600	Coax 600

Cleaning brush

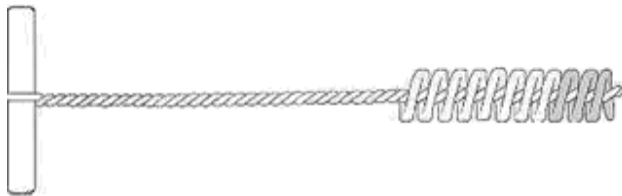

Pump



Vacuum



Dustless Drill Bit



Compressed Air

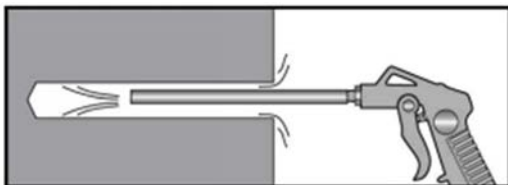

ChemSet™ Reo 502™, ChemSet™ Reo 502™EF

Intended use

Applicator Gun , Pump, Vacuum, Compressed Air, Cleaning Brush and Dustless Drill Bit

Annex B 2

Installation instructions

Installation Details – Drilling



- Drill hole to specified dimensions using carbide or diamond core as appropriate.
- Ramset™ Dustless Drilling System is recommended as the fastest most certain method of removing drilling debris and dust and eliminates post-drilling hole cleaning.
- Otherwise drilling debris and dust must be removed by brushing and blowing out of drilled holes as described below.



Carbide



Diamond Core

Hole Cleaning – Carbide Drilled



Dust removal and cleaning is not required with Ramset™ Dustless Drilling System.

Drilling debris and dust must be removed from holes drilled with standard carbide as follows:

1. Using Ramset™ blower (Part Number HCPHV), compressed air blast or wet / dry vacuum (Ramset™ AC1630P), remove dust with 2 swift pumps.
2. Using the appropriate sized brush, with a twisting / rotating motion, insert brush to the bottom of the hole and remove 2 times.
3. Remove remaining dust residue with air blower (2 pumps), compressed air blast or wet / dry vacuum.



Hole Cleaning – Core Drilled or Flooded Holes



Remove dust and drilling debris from Core drilled or flooded holes as follows:

1. Flush holes with clean running water until water is clear.
2. Using the appropriate sized brush, with a twisting / rotating motion, insert brush to the bottom of the hole and remove 2 times.
3. Flush holes with clean running water until water is clear.

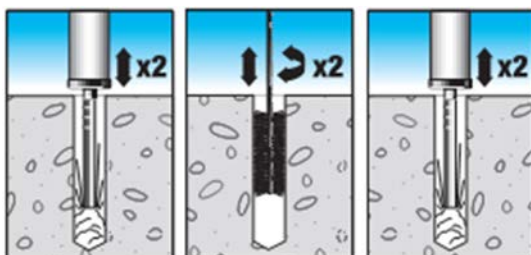
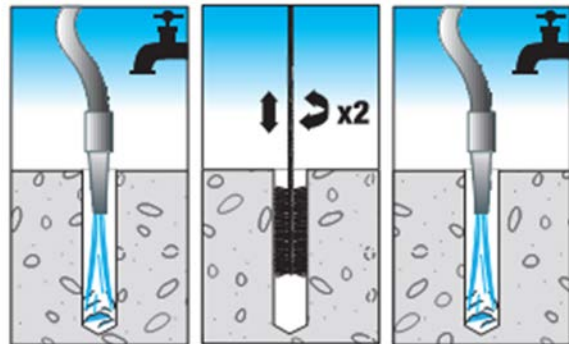

ChemSet™ Reo 502™, ChemSet™ Reo 502™EF

Intended use
Installation procedure

Annex B 3

Installation instructions (cont'd)

Opening And Using Cartridge

Manual CUAP

18V Battery CUAR18

Pneumatic CUAPN

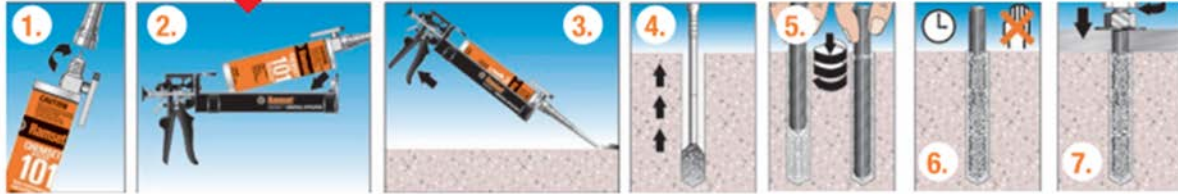

1. Remove cap from cartridge and attach mixing nozzle. Refer to product label for correct part number.
2. Load cartridge into dispensing gun (Ramset Part Numbers CUAP (Manual), CUAPN (Pneumatic) and CUAR18 (18V Battery Powered))
3. Dispense a small quantity of adhesive (2 to 3 trigger pulls) to waste to ensure both adhesive components are balanced.
4. Insert mixing nozzle tip to bottom of hole (to avoid air bubbles) and inject adhesive. Gradually withdraw nozzle to keep the nozzle tip at the surface of the adhesive. Continue injecting until hole is about $\frac{3}{4}$ filled.

5. Insert fixing using a twisting / rotating motion into adhesive and wipe away any excess. **Note: For flooded holes, insert fixing using a pushing motion**
6. Allow adhesive to cure. Refer to product label or product pages in this book or Technical Data Sheets for curing times at various temperatures.
7. Load anchor and apply torque (to threaded fixings) after appropriate cure time.



Avoid trapping air bubbles. Air bubbles reduce the bonded area resulting in a lower load capacity

Horizontal Install & Deep Embedment

- For deep holes up to 440 mm, use an extension tube (included with ISNE mixing nozzles).
- For holes deeper than 440 mm, use flexible pvc tube with a Ramset Dosing Cap (Part Number 055969).

1. Break off larger discs from Dosing Cap to obtain the correct diameter
2. Measure depth of hole.
3. Attach dosing cap to end of extension tube. Measure and mark half the hole depth on the extension tube.
4. Insert extension tube to end of hole and inject adhesive. Adhesive in the hole will apply force to the disc, pushing it back. Stop injecting when mark on tube appears.
5. Insert rod or bar with a twisting / rotating motion. Wipe away any excess adhesive.
6. Load anchor and apply torque (to threaded fixings) after appropriate cure time.

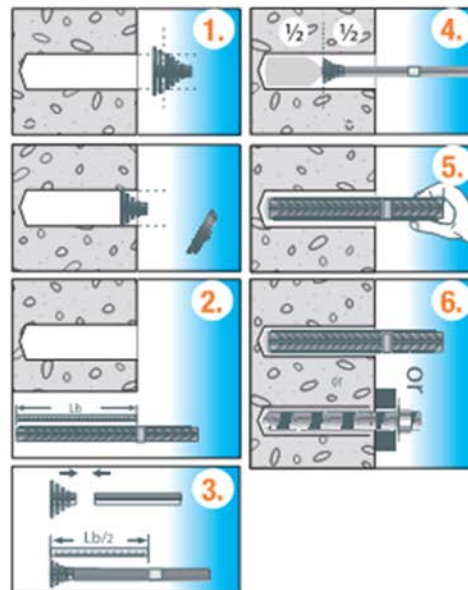

ChemSet™ Reo 502™, ChemSet™ Reo 502™EF

Annex B 3

Intended use
Installation procedure

Table B1: Installation parameters of rebar

Size			Ø12	Ø16	Ø20	Ø24	Ø25
Nominal drill hole diameter	d ₀	[mm]	16	20	25	30	30
Diameter of cleaning brush	d _{brush}	[mm]	19	22	29	40	40
Depth of drill hole – min	h _{ef,min}	[mm]	96	128	160	250	250
Minimum edge distance	c _{min}	[mm]	-	96	120	375	375
Minimum spacing	s _{min}	[mm]	-	192	240	750	750
Minimum thickness of member	h _{min}	[mm]	h _{ef} + 30 ≥ 100		h _{ef} + 2d ₀		
Depth of drill hole – max (20xd)	h _{ef,max}	[mm]	240	320	400	500	500
Minimum edge distance	c _{min}	[mm]	-	96	120	375	375
Minimum spacing	s _{min}	[mm]	-	192	240	750	750
Minimum thickness of member	h _{min}	[mm]	h _{ef} + 30 ≥ 100		h _{ef} + 2d ₀		

Table B2: Cleaning

All diameters
- 2 x blowing
- 2 x brushing
- 2 x blowing

Table B3: Minimum curing time

ChemSet™ Reo502™			
Application temperature	Processing time	Load Time	
		Dry/Wet	Flooded
+5 to +10°C	-	-	-
+10 to +15°C	27 mins	8 hours	48 hours
+15 to +20°C	23 mins	5 hours	32 hours
+20 to +25°C	20 mins	3 hours	24 hours
+25 to +30°C	12 mins	2.5 hours	15 hours
+30 to +40°C	8.5 mins	2 hours	12 hours

Processing time refers to the highest temperature in the range. Load time refers to the lowest temperature in the range. Cartridge must be conditioned to a minimum +15°C.

ChemSet™ Reo502™EF			
Application temperature	Processing time	Load Time	
		Dry/Wet	Flooded
+5 to +10°C	32 mins	96 hours	240 hours
+10 to +15°C	22 mins	48 hours	160 hours
+15 to +20°C	17 mins	22 hours	115 hours
+20 to +25°C	13 mins	12 hours	85 hours
+25 to +30°C	-	-	-
+30 to +40°C	8.5 mins	6 hours	48 hours

Processing time refers to the highest temperature in the range. Load time refers to the lowest temperature in the range. Cartridge must be conditioned to a minimum +5°C.

ChemSet™ Reo 502™, ChemSet™ Reo 502™EF

Intended use
Installation parameters
Curing time

Annex B 4

Table C1: Design method SA TS101:2015 and AS/NZS 4671:2001
Characteristic values of resistance to tension load of rebar

Steel failure – Characteristic resistance								
Size			Ø12	Ø16	Ø20	Ø24	Ø25	
Rebar Grade 500	$N_{Rk,s}$	[kN]	61	108	169	244	265	
Capacity reduction factor	$\phi_{Ms}^{1)}$	[-]	0.8					

Combined pullout and concrete cone failure in non-cracked concrete $f'c = 20$ MPa							
Size			Ø12	Ø16	Ø20	Ø24	Ø25
Characteristic bond resistance in non-cracked concrete							
Dry and wet concrete	τ_{Rk}	[N/mm ²]	9	12	12	9	9
Partial safety factor	$\phi_{Mp} = \phi_{Mc}^{1)}$	[-]	0.56 ²⁾				
Flooded hole	τ_{Rk}	[N/mm ²]	9	12	12	9	9
Capacity reduction factor	$\phi_{Mp} = \phi_{Mc}^{1)}$	[-]	0.39 ³⁾				
Factor for concrete $f'c = 50$ MPa	ψ_{Mc}	[-]	1	1.33	1.33	1	1

Concrete cone failure							
Size			Ø12	Ø16	Ø20	Ø24	Ø25
Factor according to SA TS101:2015 Section 6.2.2.2	$k_{ucr,N}$		11.0				
Edge distance	$C_{cr,N}$	[mm]	1,5 h_{ef}				
Spacing	$S_{cr,N}$	[mm]	3,0 h_{ef}				
Capacity reduction factor	$\phi_{Mc}^{1)}$	[-]	0.56 ²⁾				

Splitting failure							
Size			Ø12	Ø16	Ø20	Ø24	Ø25
Edge distance	$C_{cr,sp}$	[mm]	1,5 h_{ef}				
Spacing	$S_{cr,sp}$	[mm]	3,0 h_{ef}				
Capacity reduction factor	$\phi_{Msp}^{1)}$	[-]	0.56 ²⁾				

¹⁾ In absence of national regulations

²⁾ The capacity reduction factor for installation $\phi_{inst} 0.83$ is included

³⁾ The capacity reduction factor for installation $\phi_{inst} = 0.71$ is included

ChemSet™ Reo 502™, ChemSet™ Reo 502™EF

Performances

Design according to SA TS101 & AS/NZS 4671
Characteristic resistance for tension loads - rebar

Annex C 1

Table C2: Design method SA TS101:2015 and AS/NZS 4671:2001
Characteristic values of resistance to shear load of rebar

Steel failure without lever arm								
Size			Ø12	Ø16	Ø20	Ø24	Ø25	
Rebar Grade 500N	$V_{Rk,s}$	[kN]	37	67	105	151	164	
Capacity reduction factor	$\phi_{Ms}^{1)}$	[-]	0.67					

Steel failure with lever arm								
Size			Ø12	Ø16	Ø20	Ø24	Ø25	
Rebar Grade 500N	$M_{Rk,s}$	N.m	91	217	424	732	828	
Capacity reduction factor	$\phi_{Ms}^{1)}$	[-]	0.67					

Concrete pryout failure						
Factor k_8 from SA TS101:2015 and current experience TR 029 Design of bonded anchors, Part 5.2.3.3			2			
Capacity reduction factor	ϕ_{Mp}	[-]	0.67			

Concrete edge failure							
Size			Ø12	Ø16	Ø20	Ø24	Ø25
See section 7.2.2 of SA TS101:2015							
Capacity reduction factor	$\phi_{Mc}^{1)}$	[-]	0.67				

¹⁾ In absence of national regulations

ChemSet™ Reo 502™, ChemSet™ Reo 502™EF

Performances

Design according to SA TS101 & AS/NZS 4671
Characteristic resistance for shear loads – rebar

Annex C 2